

PS6R

Slim DIN-Rail Switching Power Supplies

Reduced size and high efficiency cuts operating costs.

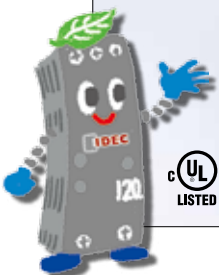

Highly efficient, low loss, high-power and space-saving switching power supplies.

IDEC, a creator of optimum HMI (Human Machine Interface) environment, has newly developed a high-power, space-saving PS6R switching power supply family. Only 37mm in width and complying with international standards. Multiple output voltages can be added easily.

Energy-saving

93% Efficiency*

Highly efficient saving energy and cost, improving productivity!

* When the input is 230V AC.

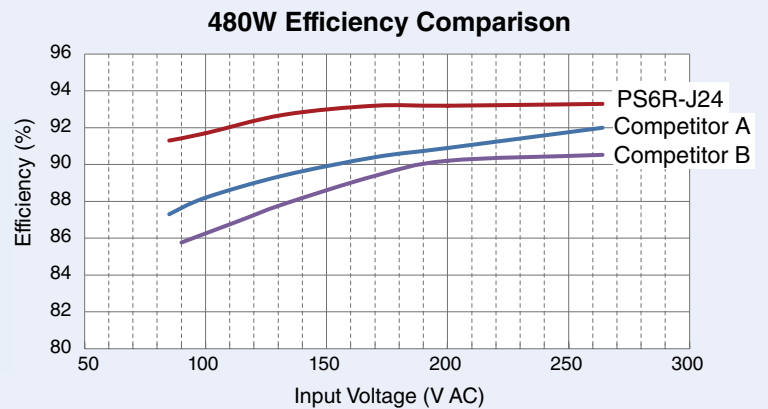

Space-saving

The slimmest switching power supplies in their class (37mm-wide, 120W model)

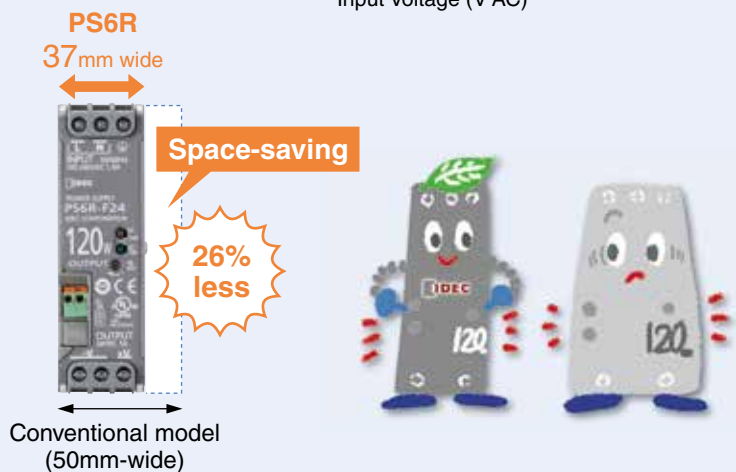

Highly Reliable

Wide operating temperature range enables stable continuous operation.

Operation without derating from 0 to 60°C.

Wide operating temperature range: -10 to +70°C.

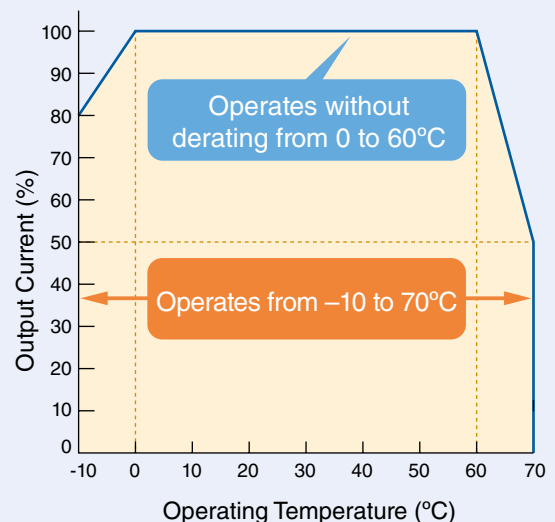

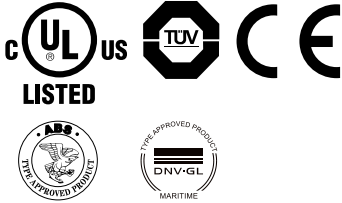

First in the industry Convenient – Easily Expandable!

Output voltages can be added or branched easily.
Less wiring reduces overall cost.

DC-DC Converter Unit

In addition to a single output, an additional 10W output can be provided.

Required space comparison (480W model)

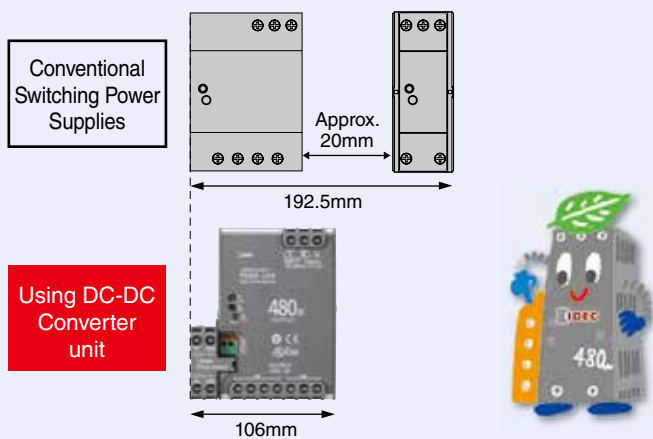

Expansion Terminal Unit

Two terminals for wiring can be added, reduces wiring and installation space.

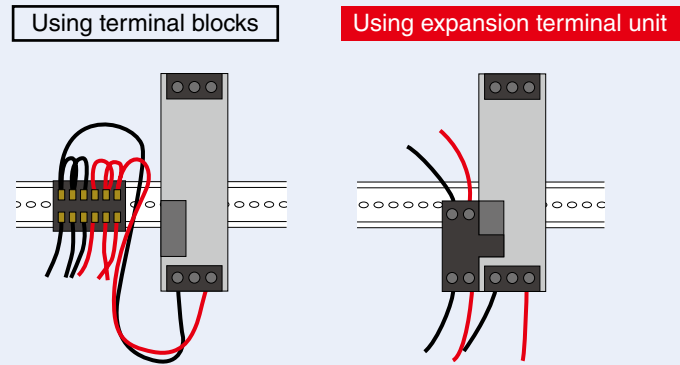

Reduces labor and improves safety

Reduced Wiring



Captive spring-up screws

Fingersafe



Terminals cannot be touched (IP20 construction), preventing electric shocks.

Captive spring-up screws will not be lost. Ring or fork terminals can be connected quickly and easily.

Easy Maintenance

LED Indicator

LED indicators make maintenance easy.

Status	Normal	Overload or Input Voltage Low (Note)	Output Short-circuit	Output OFF
DC ON (green LED)	●	●	●	●
DC Low (amber LED)	●	●	●	●

Note: The LEDs go on when the input voltage drops.

PS6R Switching Power Supplies

High-power and space-saving switching power supplies.

93% efficiency reduces running costs.

- Input voltage: 100 to 240V AC
(voltage range: 85 to 264V AC/110 to 350V DC)
- The terminals are captive spring-up screws. Ring or fork terminals can be used.
- Finger-safe construction prevents electric shocks.
- Panel mounting bracket and side-mounting panel mounting bracket. Can be attached to a DIN rail or directly to a panel surface.
- CE marking (LVD, EMC/D)
- UL (UL508, ANSI/ISA 12.12.01)
c-UL (CSA C22.2 No.107.1, No. 213)
TÜV SÜD (EN60950-1, EN50178)
- EN61204-3 (Electromagnetic compatibility Class B)
- Marine certified: ABS, DNV-GL (formerly GL)
- SEMI F47 approved (208V AC input)



Applicable Standards	Mark	File No. or Organization
UL508 ANSI/ISA 12.12.01 CSA C22.2 No. 107.1 CSA C22.2 No. 213		UL/c-UL Listed File No. E467154
EN60950-1 EN50178 EN61204-3 (Note)	 	TÜV SÜD EU Low Voltage Directive EMCD
SEMI F47	—	EPRI

Applicable Standards	Mark
ABS	
DNV-GL (formerly GL)	

Notes for marine certification:

- Side-mount panel mounting bracket (PS9Z-6R2F) is required.
- PS6R-J24 switching power supply needs a noise filter at the input (FN2070-10-06 made by SCHAFFNER).

Note: See Note 4 on page 6.

PS6R

Package Quantity: 1

Output Capacity (Note)	Part No.	Input Voltage	Output Voltage	Output Current
120W	PS6R-F24	100 to 240V AC (Voltage range: 85 to 264V AC / 110 to 350V DC)	24V	5A
240W	PS6R-G24			10A
480W	PS6R-J24			20A

Note: Output voltage × output current ≤ output capacity

Accessories

Item	Part No.	Package Quantity	Note
DC-DC Converter Unit (Note 1)	PS9Z-6RM1	1	Output: +5V, 2A, 10W
	PS9Z-6RM2		Output: +12V, 1A, 12W
	PS9Z-6RM3		Output: +5V, 1A/-5V, 1A, 10W
	PS9Z-6RM4		Output: +15V, 0.4A/-15V, 0.4A, 12W
	PS9Z-6RM5		Output: +5V, 1A/+12V, 0.5A, 11W
	PS9Z-6RM6		Output: +12V, 0.5A/-12V, 0.5A, 12W
Expansion Terminal Unit (Note 2)	PS9Z-6RS1	1	Additional screw terminals for wiring: 2 + terminals / 2 - terminals
Panel Mounting Bracket	PS9Z-6R1F	1	
Side-mount Panel Mounting Bracket (Note 3)	PS9Z-6R2F	1	Supplied with M3 × 6 countersunk mounting screws
Terminal Protection Cap	PS9Z-6CPN05	5	Used to cover the connection part of DC-DC converter unit/expansion terminal unit and PS6R.
DIN Rail	BAA1000PN10	10	Material: Aluminum, Weight: 200g
	BAP1000PN10		Material: Steel plated, Weight: 320g
Mounting Clip	BNL6PN10	10	

Note 1: When using a DC-DC converter unit, reduce 1A from the output current of the PS6R.

Note 2: When using an expansion terminal unit, the total voltage/current of PS6R and the expansion terminal unit should not exceed the rated current/voltage of PS6R.

Note 3: Use this mounting bracket when the switching power supply needs to comply with marine certification.

Reference Value

Expected Life	8 years (70,000 hours) minimum (at the rated input, duty ratio 50%, operating temperature +40°C, standard mounting direction)
---------------	---

Calculation of the expected life is based on the life of the aluminum electrolytic capacitor. The expected life is subject to operating conditions.

PS6R Switching Power Supplies

Specifications

PS6R

Part No.		PS6R-F24 (120W)	PS6R-G24 (240W)	PS6R-J24 (480W)	
Input	Input Voltage (Note 1) (Note 2)	100 to 240V AC (Voltage range: 85 to 264V AC/110 to 350V DC)			
	Frequency	50/60 Hz			
	Input Current (Typical)	100V AC	1.4A	2.7A	5.5A
		230V AC	0.7A	1.2A	2.3A
	Inrush Current	100V AC	9A max. (Ta=25°C, at cold start)		
		230V AC	20A max. (Ta=25°C, at cold start)		
	Leakage Current	120V AC	0.5mA max.		
		230V AC	1mA max.		
Efficiency (Typical) (Note 3)	100V AC	90%	90%	91%	
	230V AC	90%	91%	93%	
Power Factor (Typical)	100V AC	0.99	0.99	0.98	
	230V AC	0.96	0.97	0.97	
Output	Rated Voltage/Current	24V/5A	24V/10A	24V/20A	
	Adjustable Voltage Range	±10%			
	Output Holding Time	20ms min. (at rated input and output)			
	Start Time (Note 4)	800ms max. (at rated input and output)			
	Rise Time	200ms max. (at rated input and output)			
	Regulation	Total Fluctuation	±5% max.		
		Input Fluctuation	0.4% max.		
		Load Fluctuation	0.6% max.		
		Temperature Change	0.05%/°C max. (-10 to +60°C)		
		Ripple (including noise)	1% p-p max. (0 to +60°C) 1.5% p-p max. (-10 to 0°C)		
	Supplementary Functions	Overcurrent Protection	105 to 120% (auto reset) (output current when voltage drops by 5%)		
Overvoltage Protection		Output off at 120% (Note 5)			
Operation Indicator		LED (green)			
Voltage Low Indication		LED (amber)			
Dielectric Strength	Between input and output terminals	3000V AC, 1 minute			
	Between input and ground terminals	2000V AC, 1 minute			
	Between output and ground terminals	500V AC, 1 minute			
Insulation Resistance	100MΩ min. 500V DC megger (between input and output terminals/between input and ground terminals) (at room temperature and normal humidity)				
Operating Temperature	-10 to +70°C (no freezing) (Note 2)				
Operating Humidity	20 to 90% RH (no condensation)				
Storage Temperature	-25 to +75°C (no freezing)				
Storage Humidity	20 to 90% RH (no condensation)				
Vibration Resistance	10 to 55 Hz, amplitude 0.375 mm (using one BNL6 each on the right and left of the PS6R) 2 hours each in 3 axes, 6 directions				
Shock Resistance	300 m/s ² (150 m/s ² when using a PS9Z-6R1F panel mounting bracket), 3 times each in 6 directions (using one BNL6 each on the right and left of the PS6R)				
EMC	EMI	EN61204-3 (Class B)			
	EMS	EN61204-3 (industrial)			
Safety Standards	UL508 (UL listed), ANSI/ISA 12.12.01, CSA C22.2 No. 107.1, No. 213 (c-UL listed), IEC/EN60950-1, EN50178				
Marine Standards (Note 6)	ABS, DNV-GL (formerly GL)				
Other Standard	SEMI F47 (208V AC input only)				
Degree of Protection	IP20 (IEC 60529)				
Dimensions (mm)	125 H × 37 W × 125 D	125 H × 60 W × 125 D	125 H × 85 W × 125 D		
Weight (approx.)	630g	960g	1400g		
Terminal Screw	M3.5				

Note 1: Input voltage approved by safety standards is 100 to 240V AC. DC input is not approved by safety standards.

Note 2: For output derating curves and operating temperature approved by safety standards, see page 7.

Note 3: Under stable state.

Note 4: At light load, electric charge may remain inside the power supply after the power has turned off. Turn on the power after sufficient interval.

Note 5: Turn on the power 1 minute after the AC input is shut down.

Note 6: Use a side-mount panel mounting bracket (PS9Z-6R2F).

PS6R-J24 switching power supply needs a noise filter at the input (FN2070-10-06 made by SCHAFFNER)

PS6R Switching Power Supplies

Accessories (For use with PS6R)

Part No.		DC-DC Converter Unit (Note 5)						Expansion Terminal Unit	
		PS9Z-6RM1	PS9Z-6RM2	PS9Z-6RM3	PS9Z-6RM4	PS9Z-6RM5	PS9Z-6RM6	PS9Z-6RS1	
Output Capacity		10W max.	12W max.	10W max.	12W max.	11W max.	12W max.	—	
Output	Rated Voltage/Current	5V/2A	12V/1A	±5V/1A	±15V/0.4A	5V/1A, 12V/0.5A	±12V/0.5A	24V/10A max. (Note 1)	
	Adjustable Voltage Range	Not available							
	Voltage Accuracy	±5% max.							
	Start Time (Note 6)	200 ms max. (at rated output)							
	Regulation	Input Fluctuation	0.5% max.						
		Load Fluctuation	1.0% max.						
Temperature Change		0.05%/max. (-10 to +60°C)							
Ripple (including noise)		100mV max.	150mV max.	100mV max.	150mV max.	100mV max., 150mV max.	150mV max.	—	
Supplementary Functions	Overcurrent Protection	105% (auto reset)							
	Overvoltage Protection	Output off at 120% (Note 2)							
Operating Temperature		-10 to +70°C (no freezing) (Note 3)							
Operating Humidity		20 to 90%RH (no condensation)							
Storage Temperature		-25 to +75°C (no freezing)							
Storage Humidity		20 to 90% RH (no condensation)							
Vibration Resistance		10 to 55 Hz, amplitude 0.375 mm, 2 hours each in 3 axes, 6 directions (in combination with PS6R-F24/G24/J24)							
Shock Resistance		300 m/s ² (150 m/s ² when using a PS9Z-6R1F panel mounting bracket), 3 times each in 6 directions (in combination with PS6R-F24/G24/J24)							
EMC	EMI	EN61204-3 (Class B) (in combination with PS6R-F24/G24/J24) (Note 4)							
	EMS	EN61204-3 (industrial) (in combination with PS6R-F24/G24/J24) (Note 4)							
Safety Standards		UL508 (Listing), ANSI/ISA 12.12.01, CSA C22.2 No.107.1, No. 213 (c-UL listed), IEC/EN60950-1, EN50178 (in combination with PS6R-F24/G24/J24)							
Marine Standards		ABS, DNV-GL (formerly GL) (in combination with PS6R-F24/G24/J24)							
Degree of Protection		IP20 (IEC 60529)							
Weight (approx.)		90g							
Terminal Screw		M3.5							

Note 1: Ensure that the current does not exceed the rated current of the PS6R.

Note 2: Repair is needed when output drops due to overvoltage protection. Contact IDEC.

Note 3: For output derating curves and operating temperature approved by safety standards, see page 7.

Note 4: When using PS6R-F24/G24 with PS9Z-6RM3/6RM4/6RM6, coil each output lines of PS9Z-* around a ferrite core for one turn.

Note 5: DC-DC converter unit is non-isolated and cannot be used when insulation against PS6R output is required.

Note 6: Because each output has different start time on multi-output models, make sure of the correct operation before installation.

PS6R Switching Power Supplies

Operating Temperature vs. Output Current (Derating Curves)
PS6R-F24/G24/J24
PS9Z-6R**
 (natural air cooling)

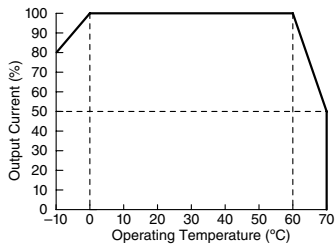

Operating temperature is the temperature around the switching power supply.

Output Current vs. Input Voltage (Derating Curves)
PS6R-F24/G24/J24
 (Ta=25°C)

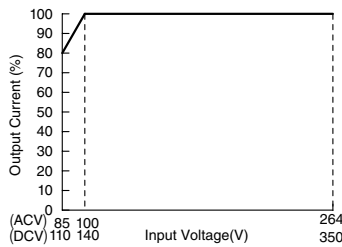

Overcurrent Protection Characteristics
PS6R-F24/G24/J24

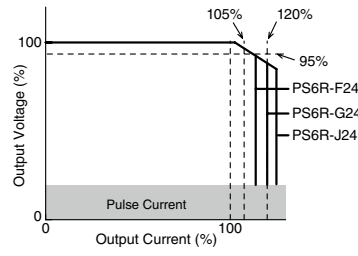

Overcurrent Protection Characteristics PS9Z-6RM*

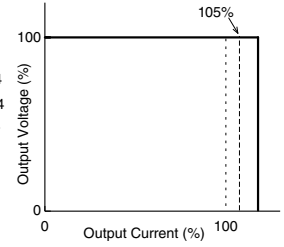

Operating Temperature approved by Safety Standards

Part No.	UL508, CSA C22.2 No. 107. 1	EN60950-1, EN50178
PS6R-F24	60°C	60°C
PS6R-G24	60°C	60°C
PS6R-J24	55°C	60°C
PS9Z-6R**	60°C	60°C

Parts Description

PS6R-F24/G24/J24
Switching Power Supply

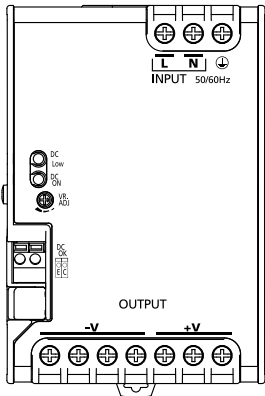

PS9Z-6RM1/M2/M5
DC-DC Converter Unit

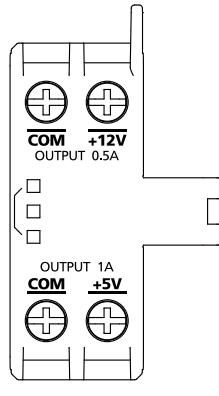

(PS6R-6RM5 shown)

PS9Z-6RM3/M4/M6
DC-DC Converter Unit

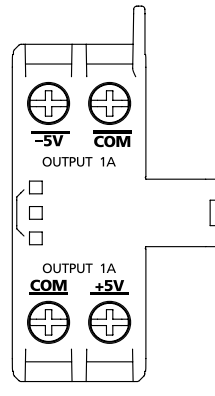

(PS6R-6RM3 shown)

PS9Z-6RS1
Expansion Terminal Unit

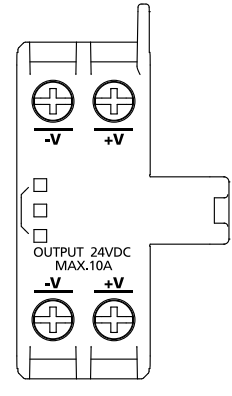

PS6R-F24/G4/J24/PS9Z-6RS1

Marking	Name	Description
L, N	Input Terminal	Voltage range: 85 to 264V AC/110 to 350V DC
⊕	Ground Terminal	Be sure to connect this terminal to a proper ground.
+V, -V	DC Output Terminals	+V: Positive output terminal -V: Negative output terminal
VR.ADJ	Output Voltage Adjustment	Allows adjustment within ±10%. Turning clockwise increases the output voltage.
DC ON	Operation Indicator (green)	Lights on when the output voltage is on.
DC LOW	Output Low Indicator (Amber)	Lights on when the output voltage drops approximately 80% of the rated value.
DC OK	DC OK Output	Lights on when the output voltage is more than 80% of the rated value. NPN transistor output (50V DC max., 50 mA max.)

PS9Z-6RM*

Marking	Name	Description
+5V, +12V, +15V	DC Output Terminal	+5V side, +12V side, +15V side: +output side
-5V, -12V, -15V	DC Output Terminal	-5V side, -12V side, -15V side: -output side
COM	DC Output Terminal	0V side (wired internally to -V of PS6R-F24/G24/J24)

PS6R Switching Power Supplies

Dimensions

PS6R-F24 (120W)

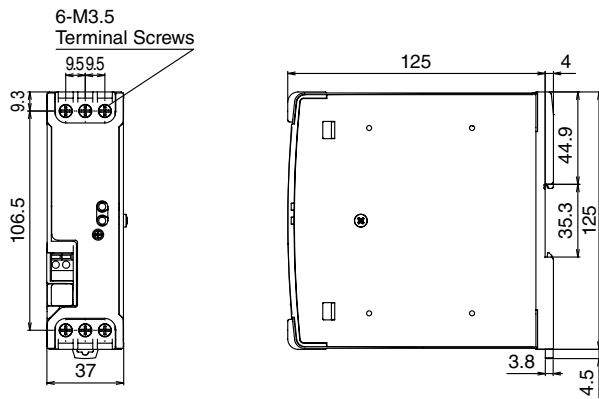

PS6R-G24 (240W)

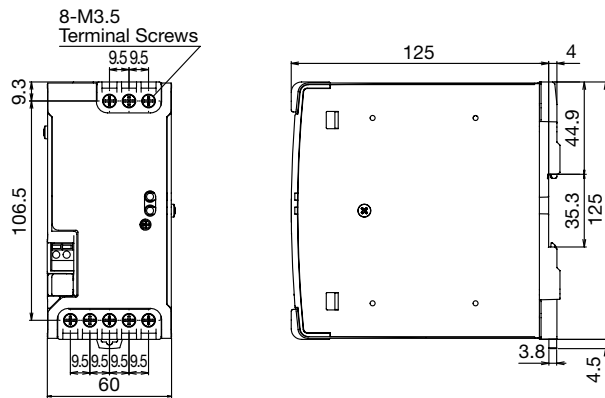

PS6R-J24 (480W)

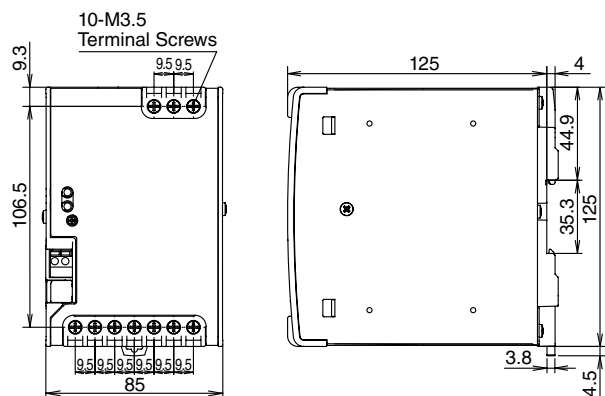

All dimensions in mm.

Tolerance: ± 1 mm

PS6R Switching Power Supplies

PS9Z-6R1F Panel Mounting Bracket

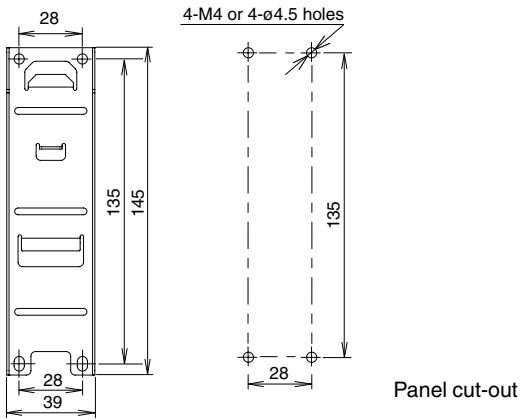

When a PS9Z-6R1F is installed on PS6R

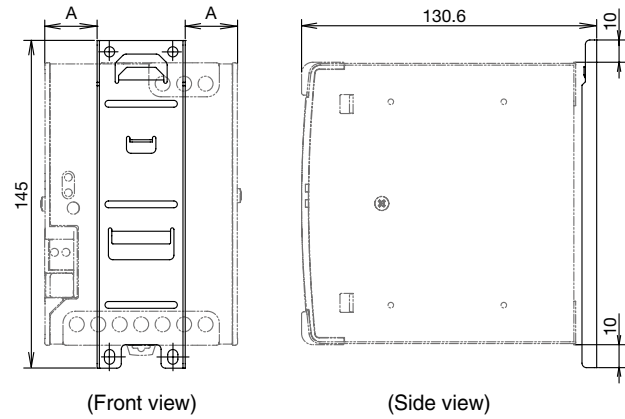

PS9Z-6R2F Side-mount Panel Mounting Bracket

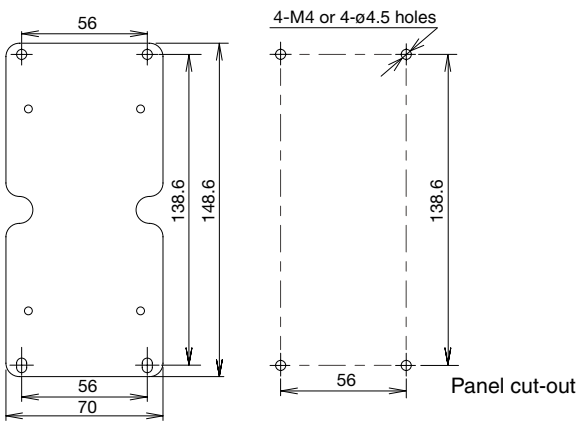

When a PS9Z-6R2F is installed on PS6R

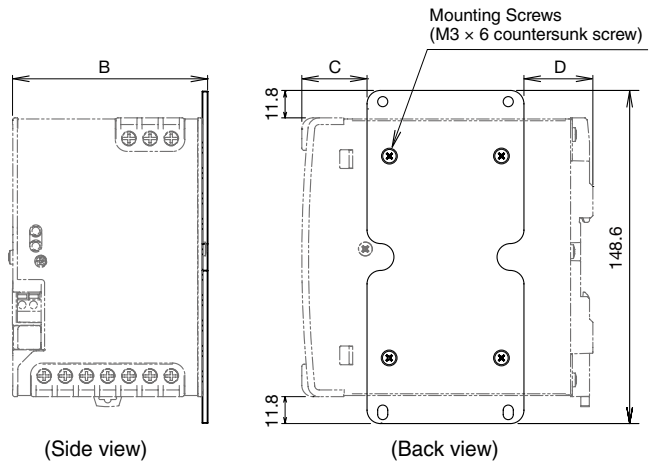

	PS6R-F24	PS6R-G24	PS6R-J24
A	—	10.5	23
B	39.3	62.3	87.3
C	29.5	29.5	29.5
D	29.5	31	31
E	58	81	106

When using a PS9Z-6RM* DC-DC Converter Unit

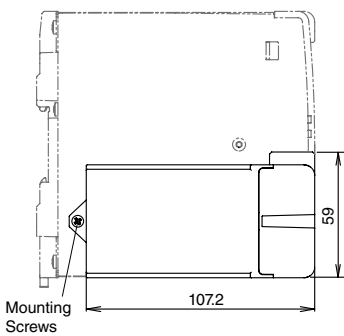

When using a PS9Z-6RS1 Expansion Terminal Unit

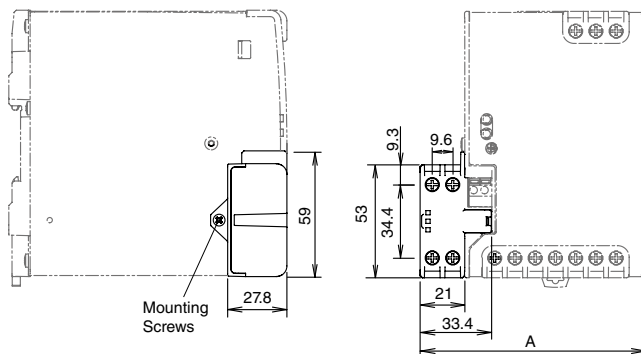

All dimensions in mm.
Tolerance: ±1mm

	PS6R-F24	PS6R-G24	PS6R-J24
A	58	81	106

PS6R Switching Power Supplies

⚠ Safety Precautions

Mount the PS6R in an enclosure. Do not use the PS6R alone as an Electric Facilities for General Use.
Use the PS6R for electric facilities for business use only.

- Do not use switching power supplies with electric equipment whose malfunction or inadvertent operation may damage the human body or life directly.
- Make sure that the input voltage and output current do not exceed the ratings. If the input voltage and output current exceed the ratings, electric shock, fire, or malfunction may occur.
- Do not touch the terminals of the switching power supply while input voltage is applied, otherwise electric shock may occur.
- Provide the final product with protection against malfunction or damage that may be caused by malfunction of the switching power supply.

- Operating temperatures should not exceed the ratings. Be sure to note the derating characteristics. If the operating temperature exceeds the ratings, electric shock, fire, or malfunction may occur.
- Blown fuses indicate that the internal circuits are damaged. Contact IDEC for repair. Do not just replace the fuse and reoperate, otherwise electric shock, fire, or malfunction may occur.
- Do not use the switching power supplies to charge rechargeable batteries.
- Do not overload or short-circuit the switching power supply for a long period of time, otherwise the internal elements may be damaged.
- Do not disassemble, repair, or modify the power supplies, otherwise the high voltage internal part may cause electric shock, fire, or malfunction.
- The fuse inside the PS6R switching power supply is for AC input. Use DC fuse for DC input.

Operating Instructions

Notes for Installation

- The PS6R can be installed in the direction shown below only.

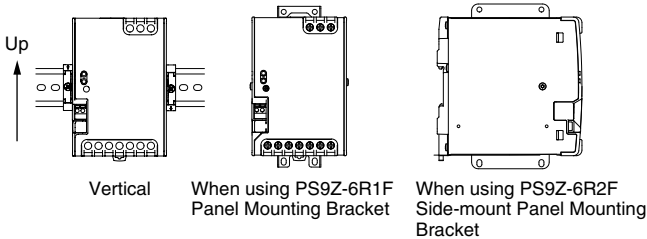

- Do not close the top and bottom openings of the PS6R to allow for heat radiation by convection.
- Maintain a minimum of 20 mm clearance around the PS6R, except for the top and bottom openings.
- When derating of the output does not work, provide forced air-cooling.
- Make sure to wire the ground terminal correctly.
- Recommended tightening torque of the input and output terminals is 1.0 to 1.3 N·m (UL compliant: 0.8 N·m).
- The output voltage can be adjusted within $\pm 10\%$ of the rated output voltage by using the V.ADJ control. Note that overvoltage protection may work when increasing the output voltage.
- When large shocks or heavy vibrations on the PS6R are expected, the use of DIN rail or PS9Z-6R2F side-mount panel mounting bracket is recommended.
- For wiring, use wires with heat resistance of 60°C or higher. Use copper wire of the following sizes. Wires of the following size must be used to comply with UL508, CSA C22.2 No. 107.1.

Model	Terminal	Wire Size/No. of Wire	Wire Type	Torque, in-ibs (N·m)
PS6R-F24 PS6R-G24	Input	18-14 AWG, 1-wire	Copper Solid/ Stranded	7.0 (0.8)
	Output	18-14 AWG, 1-wire, (18 AWG - 7A, 16 AWG - 10A, 14 AWG - 15A)		
	DC OK Output	22-14 AWG, 1-wire (stripped wire length: 6 to 7mm)		—
PS6R-J24	Input	18-14 AWG, 1-wire	Copper Solid/ Stranded Use with UL-listed ring/ folk crimp terminal.	7.0 (0.8)
	Output	18-14 AWG, 1-wire, 2-wire When using 2-wire, use the wire of the same size for each terminal (18 AWG - 7A, 16 AWG - 10A, 14 AWG - 15A)		
	DC OK Output	22-14 AWG, 1-wire (stripped wire length: 6 to 7mm)		—
PS9Z-6R*	Output	18-14 AWG, 1-wire (18 AWG - 7A, 16 AWG - 10A, 14 AWG - 15A)	Copper Solid/ Stranded	7.0 (0.8)

Cross section:

AWG22: 0.33mm², AWG20: 0.52mm², AWG18: 0.82mm²
AWG16: 1.31mm², AWG14: 2.0mm², AWG12: 3.3mm²

Applicable Crimp Terminal (reference)

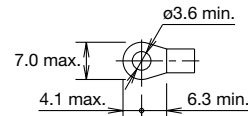

Mounting on DIN Rails

- Fasten the DIN rail to a mounting plate using screws.
- When mounting the PS6R on a DIN rail, place the PS6R as shown. With the clamp inserted, press the PS6R towards the DIN rail.
- Use end clips BNL6 for fastening the PS6R on the DIN rail. When using with a PS9Z-6RM* DC-DC converter unit, install the BNL6 on the left side of the PS6R first.

Removal

- Insert a flat screwdriver into the slot in the clamp, and pull out the clamp until it clicks. Turn the PS6R bottom out. When mounting the PS6R again, push in the latch first.

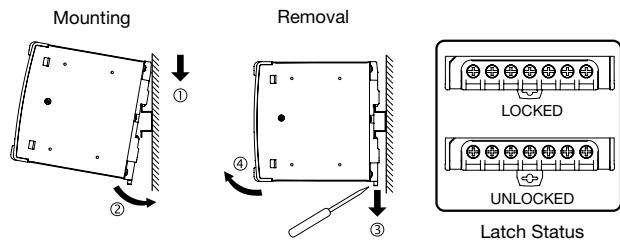

Operating Instructions

Installing the PS9Z-6R1F Panel Mounting Bracket

When excessive vibration or shock is anticipated, use the PS9Z-6R2F side-mount panel mounting bracket.

1. Push in the latch on the PS6R and insert the tab on the panel mounting bracket into the slot on the PS6R.

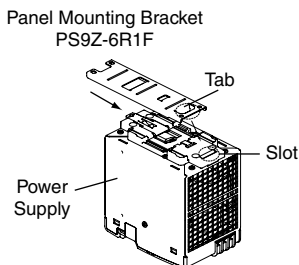

2. Install the bracket as shown below.

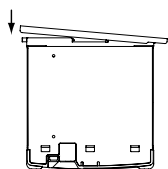

3. Ensure that the panel mounting bracket is locked by the latch.

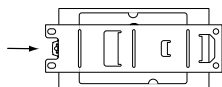

Installing the PS9Z-6R2F Panel Mounting Bracket

Install the bracket on the PS6R using the M3 x 6 countersunk mounting screws supplied with the bracket.

Recommended tightening torque: 0.5 to 0.6 N-m

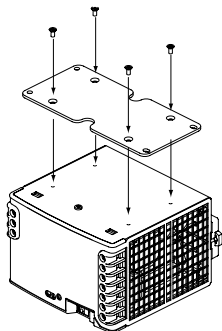

Adjustment of Output Voltage

The output voltage can be adjusted within $\pm 10\%$ of the rated output voltage by using the VR.ADJ control on the front. Turning the VR.ADJ clockwise increases the output voltage. When using a higher output voltage, reduce the output current to make sure that the output capacity is within the rating. Note that overvoltage protection may work when increasing the output voltage.

Overcurrent Protection

The output voltage drops automatically when an overcurrent flows due to an overload or short circuit. Normal voltage is automatically restored when the load returns to normal conditions.

Overvoltage Protection (OVP) PS6R-F24/G24/J24 Power Supplies

When the output voltage has dropped due to an overvoltage, turn the input off, and after one minute, turn the input on again.

PS9Z-6RM* DC-DC Converter Unit

Internal parts are damaged when the output voltage had dropped due to overvoltage. Contact IDEC.

Insulation/Dielectric Test

When performing an insulation/dielectric test, short-circuit the input (between L and N) and output (between +V and -V). Do not apply or interrupt the voltage quickly, otherwise surge voltages may be generated and the PS6R may be damaged.

Notes for Operation

1. Output interruption may indicate blown fuses. Contact IDEC.
2. The PS6R contains an internal fuse for AC input. When using DC input, install an external fuse or DC input. To avoid blown fuses, select a fuse in consideration of the rated current of the internal fuse.

Rated Current of Internal Fuses

Part No.	Internal Fuse Rated Current
PS6R-F24	4A
PS6R-G24	6.3A
PS6R-J24	10A

- Avoid overloads and short-circuits for a long period of time, otherwise internal elements may be damaged.
- DC input operation is not subjected to safety standards.

Rust and Scratches on Housing, Frame, and Metal

Parts Bonded steel plates and hot-dip galvanized steel plates are used for the PS6R switching power supplies, and may develop scratches on the surface on the edge depending on the storage condition.

Noise

Small acoustic noise inside the power supply may be heard depending on the input voltage and load, but the performance of the PS6R is not affected.

PS6R Switching Power Supplies

Operating Instructions

Series Operation

The following series operation is allowed. Connect Schottky barrier diodes D as shown below. DC-DC converter unit cannot be connected in series.

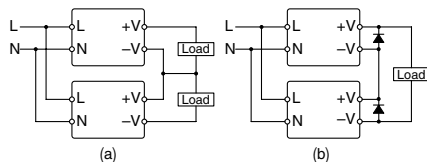

Select a Schottky diode in consideration of the rated current. The diode's reverse voltage must be higher than the PS6R's output voltage.

Parallel Operation

Parallel operation is possible to increase the output capacity. DC-DC converter unit cannot be connected in parallel.

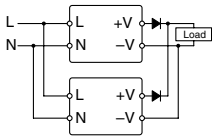

When increasing the capacity, observe the followings.

1. Maintain the operating temperature below 40°C.
2. Output cannot be connected directly in parallel operation. Connect a diode to the output of each PS6R.
3. Output terminal voltage of both power supplies must be the same. Also, maintain the voltage difference between the power supplies below 30mV.
4. Use load lines of the same diameter and length.
5. Set the output voltage higher for the amount of diode forward voltage drop.
6. Turn on the inputs at the same time.
7. Select a diode in consideration of:
Diode's reverse voltage must be higher than the PS6R's output voltage. Diode's current must be three times as the PS6R's output current. Provide a heat sink for heat dissipation.

Backup Operation

Backup operation is a connection method of two switching power supplies in parallel for emergency. Normally one switching power supply has a sufficient output. If one switching power supply fails, another one operates to continue the output. Make sure that the sum of power consumption by load and diode is not greater than the rated wattage (rated voltage × rated current) of one switching power supply.

Operating Instructions

Warranty

IDEC warrants the PS6R switching power supply for a period of three years from the date of shipment.

Scope

IDEC agrees to free repair or replacement of the PS6R switching power supply if the product has been operated under the following conditions. The maximum value of output capacity is within the range shown in "Operating Temperature vs. Output Current on page 7.

1. Average operating temperature (ambient temperature of switching power supply) is 40°C at maximum.
2. The load is 80% at maximum.
3. Input voltage is the rated input voltage.
4. Standard mounting style

IDEC shall not be liable for other damages including consequential, contingent or incidental damages. Warranty does not apply if the PS6R switching power supply was subject to:

1. Inappropriate handling, or operation beyond the specifications.
2. Modification or repair by other than IDEC.
3. Failure caused by other than the PS6R switching power supply.
4. Failure caused by natural disasters.

Specifications and other descriptions in this brochure are subject to change without notice.



IDEC CORPORATION

6-64, Nishi-Miyahara 2-Chome, Yodogawa-ku, Osaka 532-0004, Japan
Tel: +81-6-6398-2527, Fax: +81-6-6398-2547
E-mail: marketing@idec.co.jp

IDEC CORPORATION (USA)
1175 Elko Drive, Sunnyvale, CA 94089-2209, USA
Tel: +1-408-747-0550 / (800) 262-IDECE (4332)
Fax: +1-408-744-9055 / (800) 635-6246
E-mail: opencontact@idec.com

IDEC CANADA LIMITED
3155 Pepper Mill Court, Unit 4
Mississauga, Ontario, L5L 4X7, Canada
Tel: +1-905-890-8561, Toll Free: (888) 317-IDECE (4332)
Fax: +1-905-890-8562
E-mail: sales@ca.idec.com

IDEC AUSTRALIA PTY. LTD.
Unit 17, 104 Ferntree Gully Road,
Oakleigh, Victoria 3166, Australia
Tel: +61-3-8523-5900, Toll Free: 1800-68-4332
Fax: +61-3-8523-5999
E-mail: sales@au.idec.com

IDEC ELEKTROTECHNIK GmbH
Heselerstrucken 8, 22453 Hamburg, Germany
Tel: +49-40-25 30 54 - 0, Fax: +49-40-25 30 54 - 24
E-mail: service@eu.idec.com

IDEC (SHANGHAI) CORPORATION
Room 701-702 Chong Hing Finance Center,
No. 288 Nanjing Road West, Shanghai 200003, PRC
Tel: +86-21-6135-1515
Fax: +86-21-6135-6225 / +86-21-6135-6226
E-mail: idec@cn.idec.com

IDEC (BEIJING) CORPORATION
Room 211B, Tower B, The Grand Pacific Building,
8A Guanghua Road, Chaoyang District,
Beijing 100026, PRC

Tel: +86-10-6581-6131, Fax: +86-10-6581-5119

IDEC (SHENZHEN) CORPORATION
Unit AB-3B2, Tian Xiang Building, Tian'an Cyber Park,
Fu Tian District, Shenzhen, Guang Dong 518040, PRC
Tel: +86-755-8356-2977, Fax: +86-755-8356-2944

IDEC IZUMI (H.K.) CO., LTD.
Unit G & H, 26/F, MG Tower, No. 133 Hoi Bun Road,
Kwun Tong, Kowloon, Hong Kong
Tel: +852-2803-8989, Fax: +852-2565-0171
E-mail: info@hk.idec.com

IDEC TAIWAN CORPORATION
8F-1, No. 79, Hsin Tai Wu Road, Sec. 1,
Hsi-Chih District, 22101 New Taipei City, Taiwan
Tel: +886-2-2698-3929, Fax: +886-2-2698-3931
E-mail: service@tw.idec.com

IDEC IZUMI ASIA PTE. LTD.
No. 31, Tannery Lane #05-01,
HB Centre 2, Singapore 347788
Tel: +65-6746-1155, Fax: +65-6844-5995
E-mail: info@sg.idec.com

IDEC ASIA (THAILAND) CO., LTD.
20th Fl., Sorachai Bldg., No.23/78,
Soi Sukhumvit 63, Sukhumvit Rd.,
Klongton-nua, Wattana, Bangkok 10110
Tel: +662-392-9765, Fax: +662-392-9768
E-mail: sales@th.idec.com